

**H8S/2635 FP-128**  
**User System Interface Cable**  
HS2635ECH61H User's Manual

Renesas Microcomputer Development Environment System

H8S Family / H8S/2600 Series

HS2635ECH61HE

Rev.1.00  
Revision Date: Jun. 10, 2005

RenesasTechnology  
[www.renesas.com](http://www.renesas.com)

User's Manual



## Keep safety first in your circuit designs!

1. Renesas Technology Corp. puts the maximum effort into making semiconductor products better and more reliable, but there is always the possibility that trouble may occur with them. Trouble with semiconductors may lead to personal injury, fire or property damage.  
Remember to give due consideration to safety when making your circuit designs, with appropriate measures such as (i) placement of substitutive, auxiliary circuits, (ii) use of nonflammable material or (iii) prevention against any malfunction or mishap.

## Notes regarding these materials

1. These materials are intended as a reference to assist our customers in the selection of the Renesas Technology Corp. product best suited to the customer's application; they do not convey any license under any intellectual property rights, or any other rights, belonging to Renesas Technology Corp. or a third party.
2. Renesas Technology Corp. assumes no responsibility for any damage, or infringement of any third-party's rights, originating in the use of any product data, diagrams, charts, programs, algorithms, or circuit application examples contained in these materials.
3. All information contained in these materials, including product data, diagrams, charts, programs and algorithms represents information on products at the time of publication of these materials, and are subject to change by Renesas Technology Corp. without notice due to product improvements or other reasons. It is therefore recommended that customers contact Renesas Technology Corp. or an authorized Renesas Technology Corp. product distributor for the latest product information before purchasing a product listed herein.  
The information described here may contain technical inaccuracies or typographical errors.  
Renesas Technology Corp. assumes no responsibility for any damage, liability, or other loss rising from these inaccuracies or errors.  
Please also pay attention to information published by Renesas Technology Corp. by various means, including the Renesas Technology Corp. Semiconductor home page (<http://www.renesas.com>).
4. When using any or all of the information contained in these materials, including product data, diagrams, charts, programs, and algorithms, please be sure to evaluate all information as a total system before making a final decision on the applicability of the information and products. Renesas Technology Corp. assumes no responsibility for any damage, liability or other loss resulting from the information contained herein.
5. Renesas Technology Corp. semiconductors are not designed or manufactured for use in a device or system that is used under circumstances in which human life is potentially at stake. Please contact Renesas Technology Corp. or an authorized Renesas Technology Corp. product distributor when considering the use of a product contained herein for any specific purposes, such as apparatus or systems for transportation, vehicular, medical, aerospace, nuclear, or undersea repeater use.
6. The prior written approval of Renesas Technology Corp. is necessary to reprint or reproduce in whole or in part these materials.
7. If these products or technologies are subject to the Japanese export control restrictions, they must be exported under a license from the Japanese government and cannot be imported into a country other than the approved destination.  
Any diversion or reexport contrary to the export control laws and regulations of Japan and/or the country of destination is prohibited.
8. Please contact Renesas Technology Corp. for further details on these materials or the products contained therein.



# IMPORTANT INFORMATION

## READ FIRST

- **READ** this user's manual before using this user system interface cable.
- **KEEP the user's manual handy for future reference.**

**Do not attempt to use the user system interface cable until you fully understand its mechanism.**

### **User System Interface Cable:**

Throughout this document, the term "user system interface cable" shall be defined as the following product produced only by Renesas Technology Corp. excluding all subsidiary products.

- User system interface cable (HS2635ECH61H)

The user system or a host computer is not included in this definition.

### **Purpose of the User System Interface Cable:**

This user system interface cable is for connecting the emulator station and user system. This user system interface cable must only be used for the above purpose.

### **Improvement Policy:**

Renesas Technology Corp. (including its subsidiaries, hereafter collectively referred to as Renesas) pursues a policy of continuing improvement in design, performance, functions, and safety of the user system interface cable. Renesas reserves the right to change, wholly or partially, the specifications, design, user's manual, and other documentation at any time without notice.

### **Target User of the User System Interface Cable:**

This user system interface cable should only be used by those who have carefully read and thoroughly understood the information and restrictions contained in the user's manual. Do not attempt to use the user system interface cable until you fully understand its mechanism.

It is highly recommended that first-time users be instructed by users that are well versed in the operation of the user system interface cable.

## **LIMITED WARRANTY**

Renesas warrants its user system interface cables to be manufactured in accordance with published specifications and free from defects in material and/or workmanship. Renesas will repair or replace any user system interface cables determined to be defective in material and/or workmanship. User system interface cables are wearing parts which Renesas will not repair or replace if damaged and/or worn through use. The foregoing shall constitute the sole remedy for any breach of Renesas' warranty. This warranty extends only to you, the original Purchaser. It is not transferable to anyone who subsequently purchases the user system interface cable from you. Renesas is not liable for any claim made by a third party or made by you for a third party.

## **DISCLAIMER**

RENESAS MAKES NO WARRANTIES, EITHER EXPRESS OR IMPLIED, ORAL OR WRITTEN, EXCEPT AS PROVIDED HEREIN, INCLUDING WITHOUT LIMITATION THEREOF, WARRANTIES AS TO MARKETABILITY, MERCHANTABILITY, FITNESS FOR ANY PARTICULAR PURPOSE OR USE, OR AGAINST INFRINGEMENT OF ANY PATENT. IN NO EVENT SHALL RENESAS BE LIABLE FOR ANY DIRECT, INCIDENTAL OR CONSEQUENTIAL DAMAGES OF ANY NATURE, OR LOSSES OR EXPENSES RESULTING FROM ANY DEFECTIVE USER SYSTEM INTERFACE CABLE, THE USE OF ANY USER SYSTEM INTERFACE CABLE, OR ITS DOCUMENTATION, EVEN IF ADVISED OF THE POSSIBILITY OF SUCH DAMAGES. EXCEPT AS EXPRESSLY STATED OTHERWISE IN THIS WARRANTY, THIS USER SYSTEM INTERFACE CABLE IS SOLD "AS IS", AND YOU MUST ASSUME ALL RISK FOR THE USE AND RESULTS OBTAINED FROM THE USER SYSTEM INTERFACE CABLE.

**State Law:**

Some states do not allow the exclusion or limitation of implied warranties or liability for incidental or consequential damages, so the above limitation or exclusion may not apply to you. This warranty gives you specific legal rights, and you may have other rights which may vary from state to state.

**The Warranty is Void in the Following Cases:**

Renesas shall have no liability or legal responsibility for any problems caused by misuse, abuse, misapplication, neglect, improper handling, installation, repair or modifications of the user system interface cable without Renesas' prior written consent or any problems caused by the user system.

**All Rights Reserved:**

This user's manual and user system interface cable are copyrighted and all rights are reserved by Renesas. No part of this user's manual, all or part, may be reproduced or duplicated in any form, in hard-copy or machine-readable form, by any means available without Renesas' prior written consent.

**Other Important Things to Keep in Mind:**

1. Circuitry and other examples described herein are meant merely to indicate the characteristics and performance of Renesas' semiconductor products. Renesas assumes no responsibility for any intellectual property claims or other problems that may result from applications based on the examples described herein.
2. No license is granted by implication or otherwise under any patents or other rights of any third party or Renesas.

**Figures:**

Some figures in this user's manual may show items different from your actual system.

**Limited Anticipation of Danger:**

Renesas cannot anticipate every possible circumstance that might involve a potential hazard. The warnings in this user's manual and on the user system interface cable are therefore not all inclusive. Therefore, you must use the user system interface cable safely at your own risk.

# SAFETY PAGE

## READ FIRST

- **READ** this user's manual before using this user system interface cable.
- **KEEP** the user's manual handy for future reference.

Do not attempt to use the user system interface cable until you fully understand its mechanism.

## DEFINITION OF SIGNAL WORDS



This is the safety alert symbol. It is used to alert you to potential personal injury hazards. Obey all safety messages that follow this symbol to avoid possible injury or death.



**DANGER** indicates an imminently hazardous situation which, if not avoided, will result in death or serious injury.



**WARNING** indicates a potentially hazardous situation which, if not avoided, could result in death or serious injury.



**CAUTION** indicates a potentially hazardous situation which, if not avoided, may result in minor or moderate injury.



**CAUTION** used without the safety alert symbol indicates a potentially hazardous situation which, if not avoided, may result in property damage.

**NOTE** emphasizes essential information.



# **WARNING**

**Observe the precautions listed below. Failure to do so will result in a FIRE HAZARD and will damage the user system and the emulator product or will result in PERSONAL INJURY. The USER PROGRAM will be LOST.**

- 1. Do not repair or remodel the emulator product by yourself for electric shock prevention and quality assurance.**
- 2. Always switch OFF the E6000 emulator and user system before connecting or disconnecting any CABLES or PARTS.**
- 3. Always before connecting any CABLES, make sure that pin 1 on both sides are correctly aligned.**

# Preface

Thank you for purchasing this user system interface cable (HS2635ECH61H) for the Renesas' original microcomputer H8S/2635 group.

The HS2635ECH61H is a user system interface cable that connects an H8S/2635, H8S/2636, and H8S/2646 group E6000 emulator (HS2646EPI61H; hereinafter referred to as the emulator) to the IC socket for an FP-128 package for the H8S/2635 group MCU on the user system.

# Contents

Section 1	Configuration.....	1
Section 2	Connection Procedures .....	4
2.1	Connecting User System Interface Cable to Emulator Station .....	4
2.2	Connecting User System Interface Cable to User System .....	6
2.2.1	Installing IC Socket.....	6
2.2.2	Soldering IC Socket .....	7
2.2.3	Inserting Cable Head.....	7
2.2.4	Fastening Cable Head .....	8
2.2.5	Fastening Cable Body .....	10
2.3	Recommended Dimensions for User System Mount Pad .....	11
2.4	Dimensions for User System Interface Cable Head.....	12
2.5	Resulting Dimensions after Connecting User System Interface Cable .....	13
Section 3	Installing the MCU to the User System.....	14
Section 4	Verifying Operation.....	16
Section 5	Notice.....	17

## Section 1 Configuration

### **CAUTION**

**Use an NQPACK128RD socket (manufactured by Tokyo Eletech Corporation) for the FP-128 package IC socket on the user system.**

Figure 1 shows the configuration of the HS2635ECH61H user system interface cable for the FP-128 package.

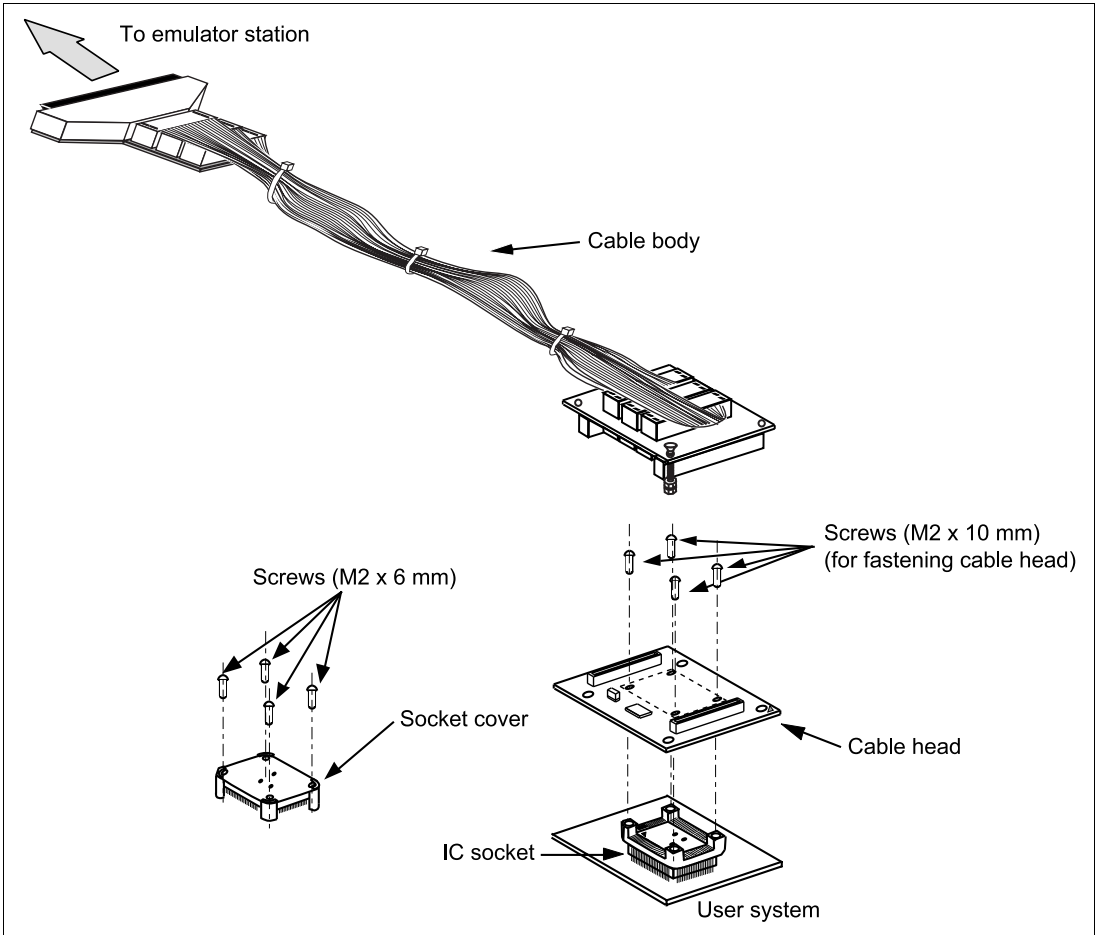

**Figure 1 HS2635ECH61H User System Interface Cable**

Table 1 lists the HS2635ECH61H components. Please make sure you have all of these components when unpacking.

**Table 1      HS2635ECH61H Components**

<b>No.</b>	<b>Component</b>	<b>Quantity</b>	<b>Remarks</b>
1	Cable body	1	Flat cable
2	Cable head	1	
3	IC socket	1	For the FP-128 package
4	Socket cover	1	For installing an FP-128 packaged MCU
5	Screws (M2 × 10 mm)	4	For fastening cable head
6	Screws (M2 × 6 mm)	4	For installing an FP-128 packaged MCU
7	Guide pins	3	For determining the IC socket location
8	Screwdriver	1	For tightening screws
9	Documentation	1	User's manual for HS2635ECH61H (this manual)

## Section 2 Connection Procedures

### 2.1 Connecting User System Interface Cable to Emulator Station

#### **WARNING**

**Observe the precautions listed below. Failure to do so will result in a FIRE HAZARD and will damage the user system and the emulator product or will result in PERSONAL INJURY. The USER PROGRAM will be LOST.**

- 1. Always switch OFF the user system and the emulator product before the USER SYSTEM INTERFACE CABLE is connected to or removed from any part. Before connecting, make sure that pin 1 on both sides are correctly aligned.**
- 2. The user system interface cable dedicated to the emulator must be used.**

To connect the cable body to the emulator station, follow the instructions below.

1. Make sure the user system and emulator station are turned off.

#### **CAUTION**

**When connecting or removing the user system interface cable, apply force only in the direction suitable for connection or removal, while making sure not to bend or twist the cable or connectors. Otherwise, the connectors will be damaged.**

2. After making sure the direction of the cable body connector is correct, firmly insert the cable body connector into the emulator station socket (figure 2).

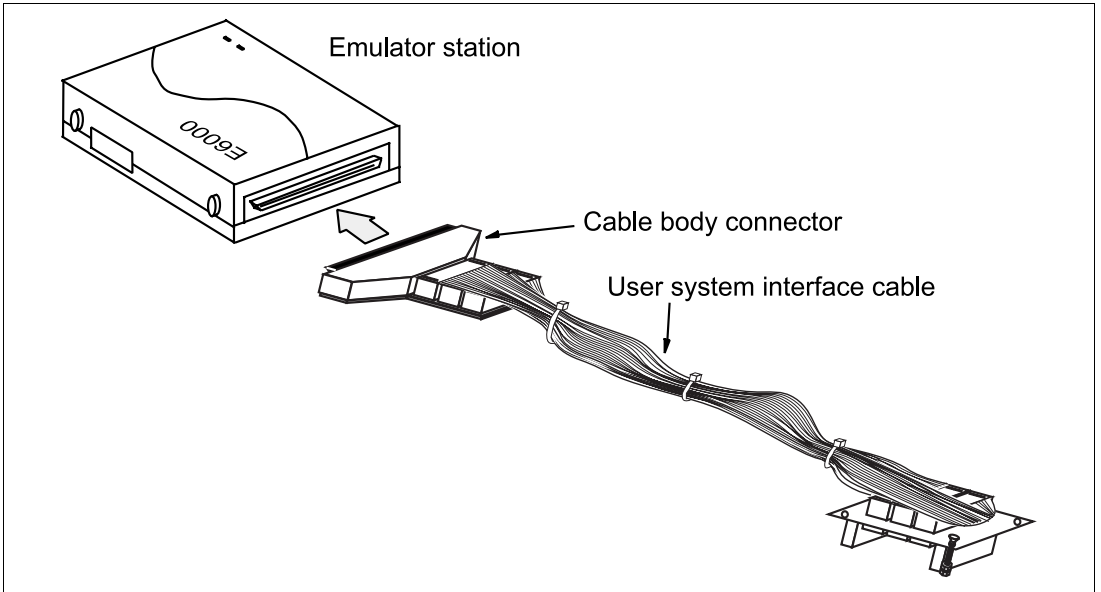

**Figure 2 Connecting User System Interface Cable to Emulator Station**



## 2.2 Connecting User System Interface Cable to User System

### **WARNING**

**Always switch OFF the user system and the emulator product before the USER SYSTEM INTERFACE CABLE is connected to or removed from any part. Before connecting, make sure that pin 1 on both sides are correctly aligned. Failure to do so will result in a FIRE HAZARD and will damage the user system and the emulator product or will result in PERSONAL INJURY. The USER PROGRAM will be LOST.**

To connect the cable head to the user system, follow the instructions below.

### 2.2.1 Installing IC Socket

After checking the location of pin 1 on the IC socket, determine where to install the IC socket by using the guide pins provided as shown in figure 3. Apply epoxy resin adhesive to the end of the four projections at the bottom of the IC socket, and fasten it to the user system before soldering.

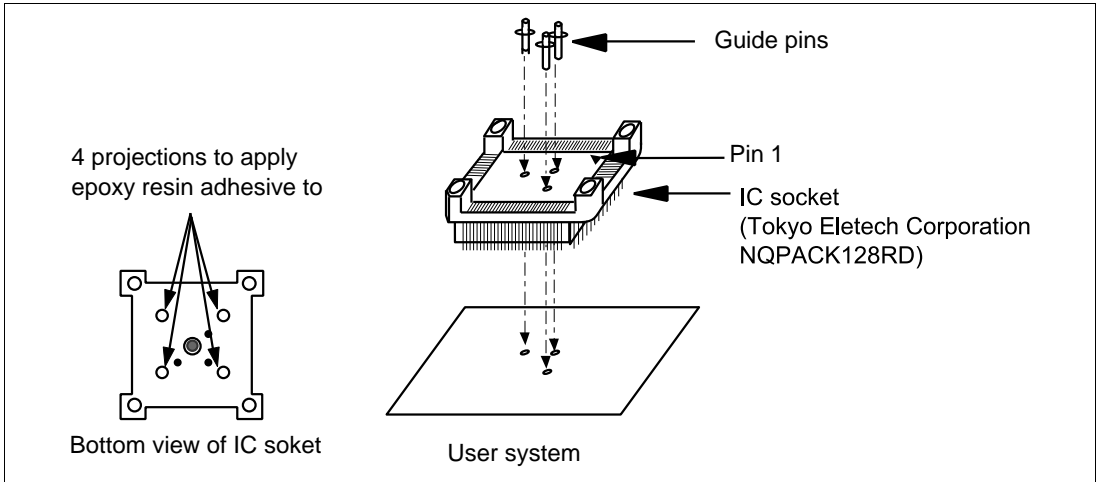

**Figure 3 Location Setting of IC Socket**

### 2.2.2 Soldering IC Socket

After fastening, solder the IC socket for an FP-128 package to the user system. Be sure to completely solder the leads so that the solder slops gently over the leads and forms solder fillets. (Use slightly more solder than the MCU.)

### 2.2.3 Inserting Cable Head

## CAUTION

**Check the location of pin 1 before inserting.**

Align pin 1 on the IC socket for an FP-128 package on the user system with pin 1 on the user system interface cable head, and insert the user system interface cable head into the IC socket on the user system, as shown in figure 4.

## CAUTION

1. Use the screwdriver provided for tightening screws.
2. The tightening torque must be 0.054 N•m or less.  
If the applied torque cannot be accurately measured, stop tightening when the force required to turn the screw becomes significantly greater than that needed when first tightening. If a screw is tightened too much, the screw head may break or an IC socket contact error may be caused by a crack in the IC socket solder.
3. If the emulator does not operate correctly, cracks might have occurred in the solder. Check conduction with a tester and re-solder the IC socket if necessary.

Fasten the user system interface cable head to the IC socket for an FP-128 package on the user system with the four screws (M2 × 10 mm) provided. Each screw should be tightened a little at a time, alternating between screws on opposing corners. Take special care, such as manually securing the IC socket soldered area, to prevent the soldered IC socket from being damaged by overtightening the screws or twisting the components.

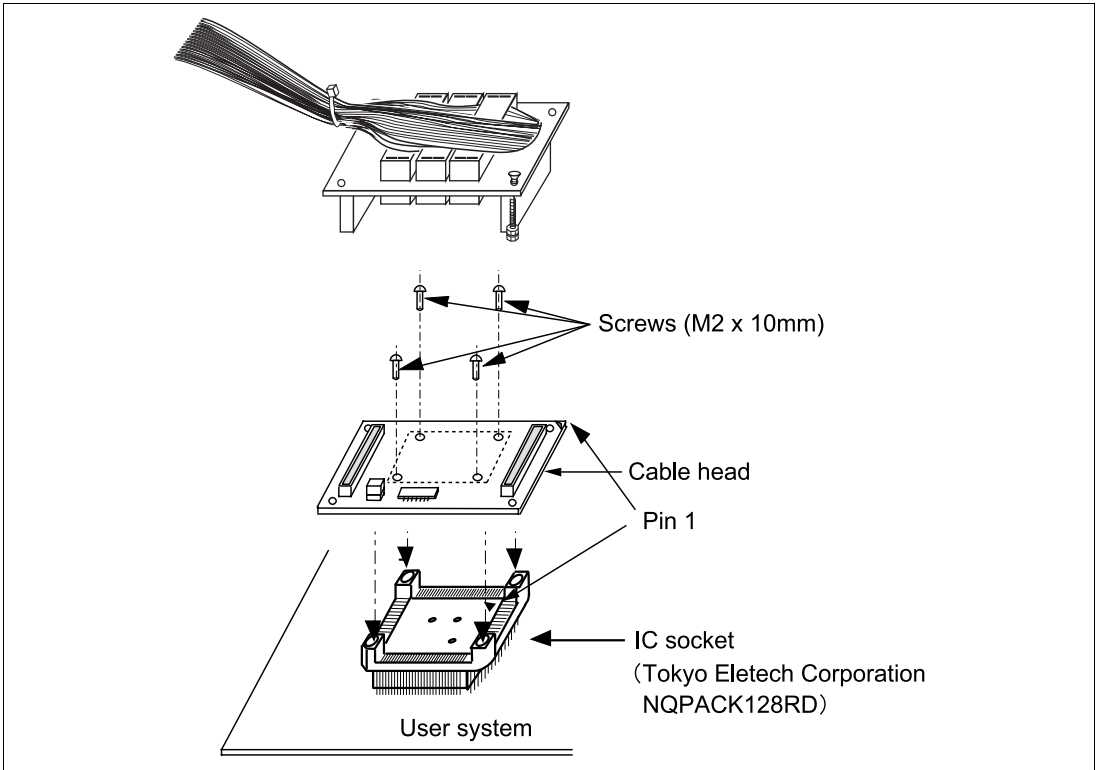

**Figure 4 Connecting User System Interface Cable to User System**

## 2.2.5 Fastening Cable Body

Connect the cable body to the cable head.

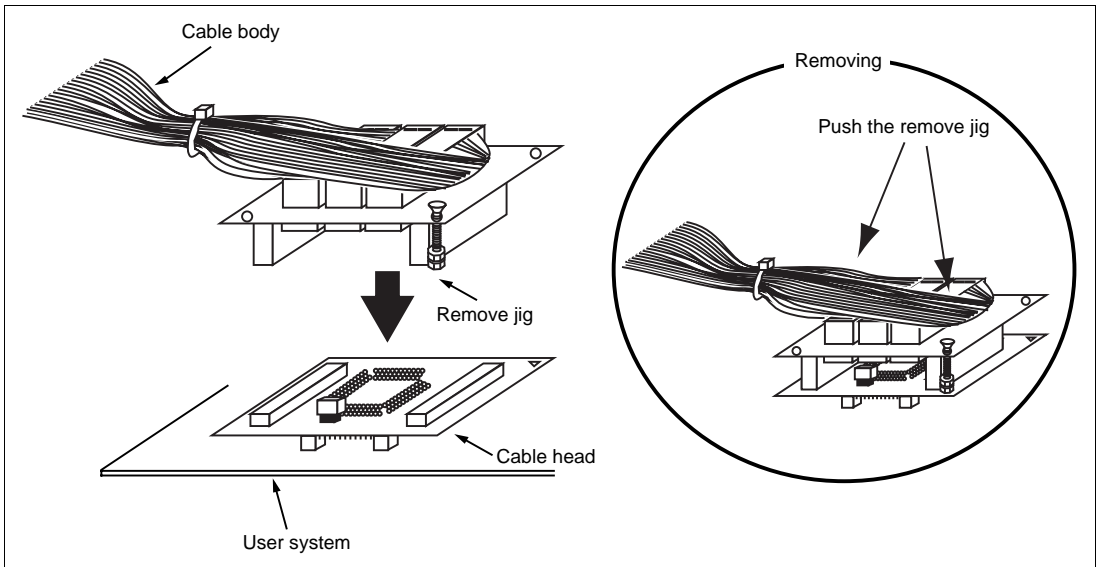

**Figure 5 Fastening Cable Body**

## 2.3 Recommended Dimensions for User System Mount Pad

Figure 6 shows the recommended dimensions for the mount pad (footprint) for the user system with an IC socket for an FP-128 package (NQPACK128RD: manufactured by Tokyo Eletech Corporation). Note that the dimensions in figure 6 are somewhat different from those of the actual MCU's mount pad.

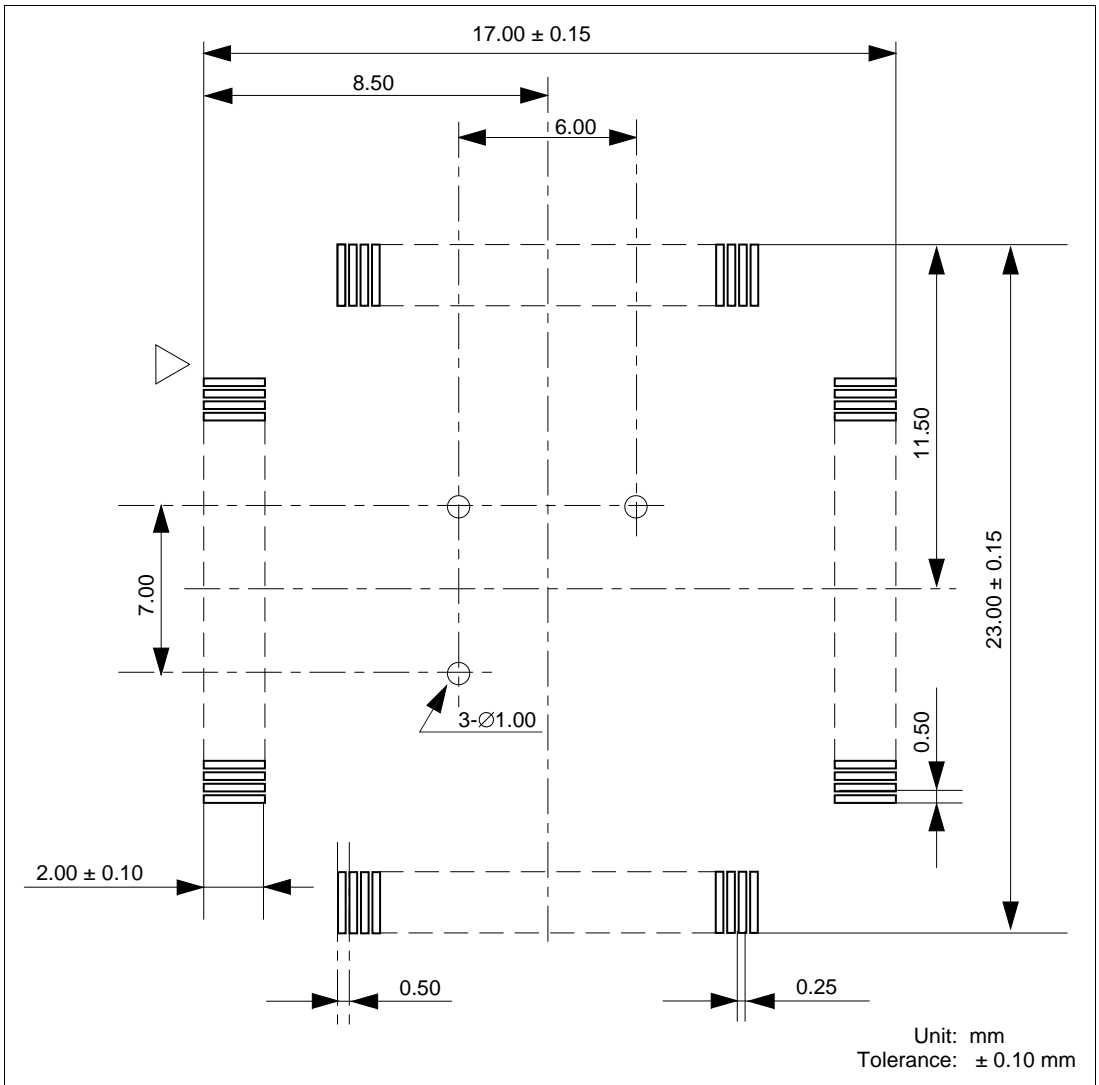
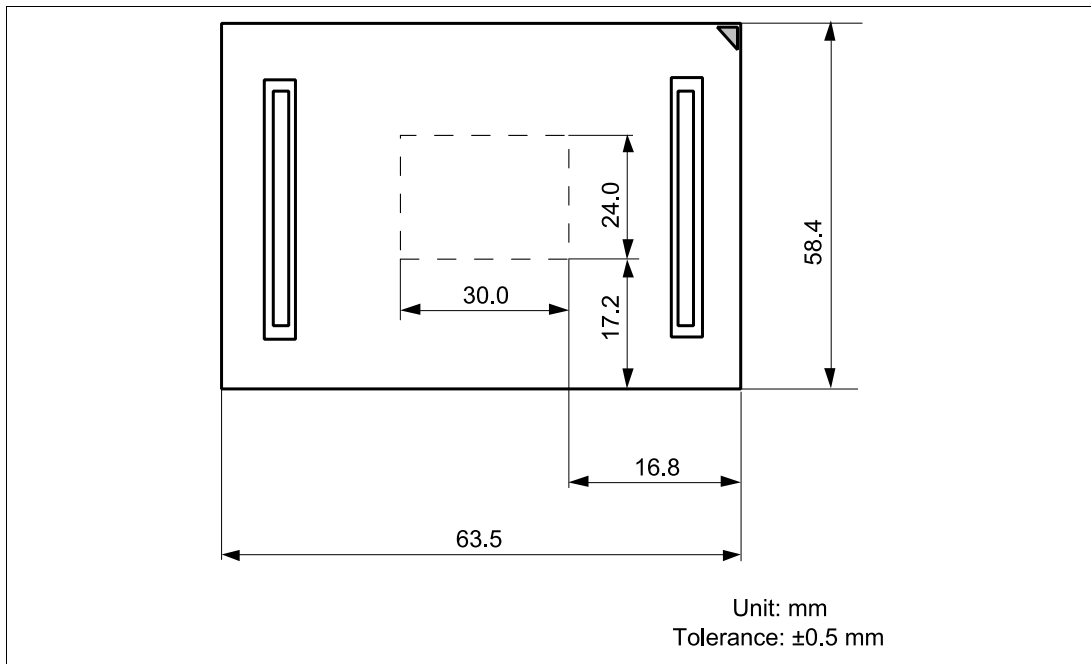

Figure 6 Recommended Dimensions for Mount Pad

## 2.4 Dimensions for User System Interface Cable Head

The dimensions for the user system interface cable head are shown in figure 7.



**Figure 7 Dimensions for User System Interface Cable Head**

## 2.5 Resulting Dimensions after Connecting User System Interface Cable

The resulting dimensions, after connecting the user system interface cable head to the user system, are shown in figure 8.

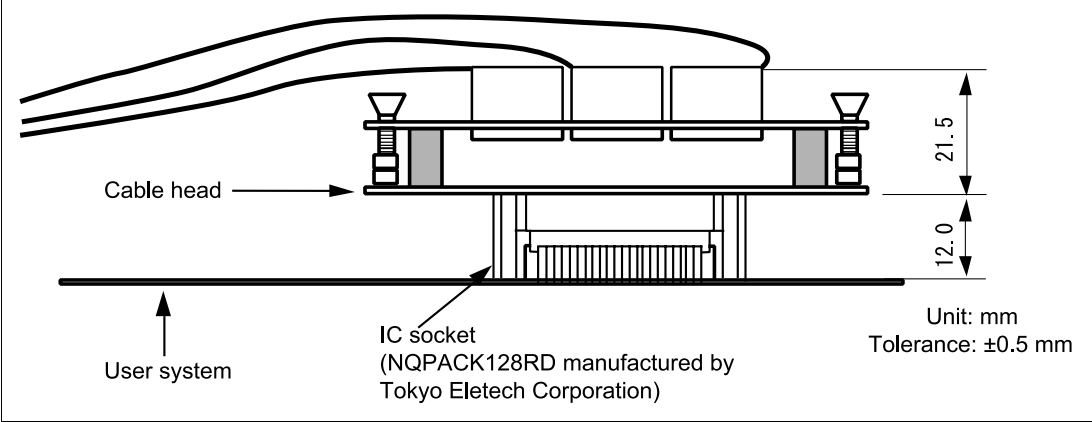

**Figure 8 Resulting Dimensions after Connecting User System Interface Cable**



## Section 3 Installing the MCU on the User System

### CAUTION

1. Check the location of pin 1 before inserting.
2. Use the screwdriver provided for tightening screws.
3. The tightening torque must be 0.054 N•m or less.  
If the applied torque cannot be accurately measured, stop tightening when the force required to turn the screw becomes significantly greater than that needed when first tightening. If a screw is tightened too much, the screw head may break or an IC socket contact error may be caused by a crack in the IC socket solder.
4. If the MCU does not operate correctly, cracks might have occurred in the solder. Check conduction with a tester and re-solder the IC socket if necessary.

Check the location of pin 1 before inserting the MCU into the IC socket on the user system, as shown in figure 9. After inserting the MCU, fasten the socket cover with the provided four screws (M2 × 6 mm). Take special care, such as manually securing the IC socket soldered area, to prevent the IC socket from being damaged by overtightening the screws or twisting the components.

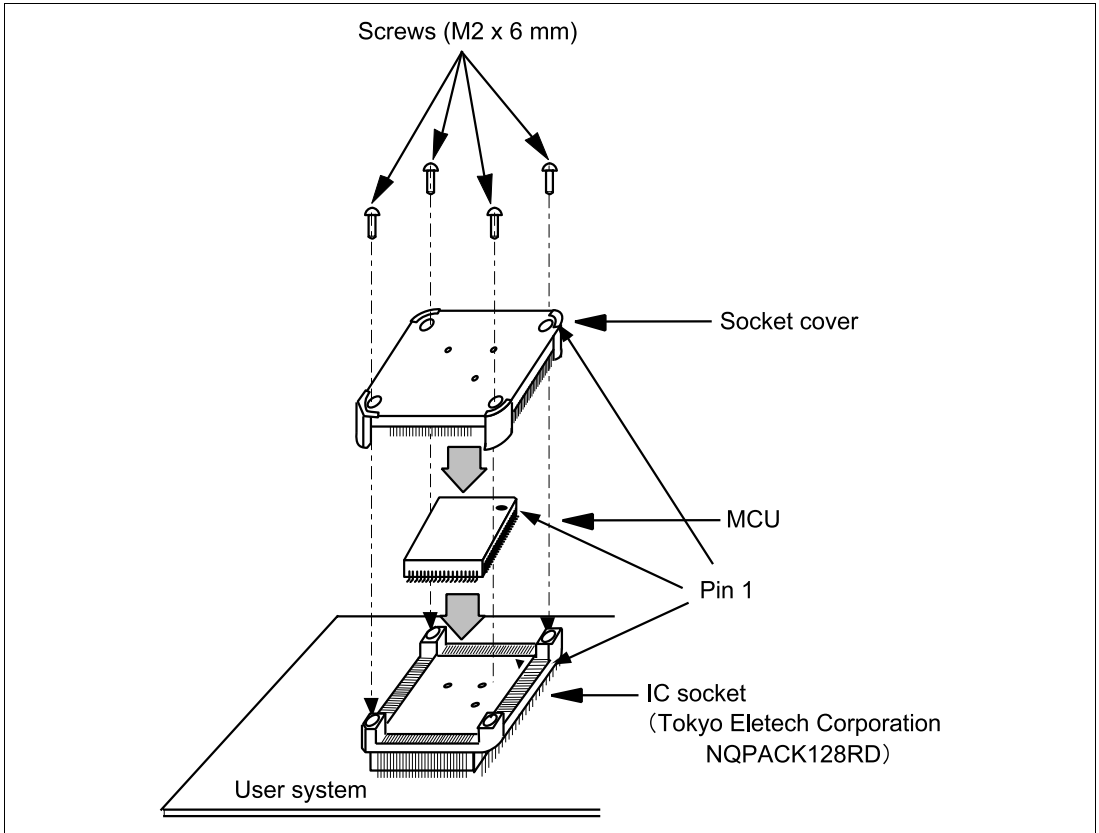
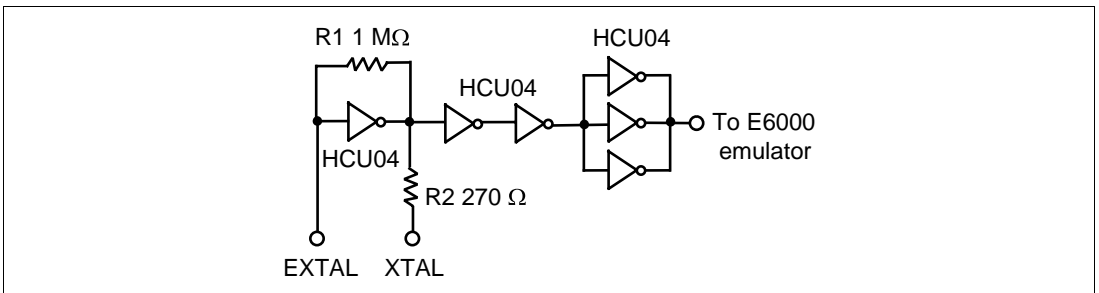

**Figure 9 Installing MCU to User System**

## Section 4 Verifying Operation

1. Start up the emulator according to the procedures described in the H8S/2646 E6000 Emulator User's Manual (HS2646EPI61HE).
2. Verify the user system interface cable connections by accessing the external memory and ports to check the bus states of the pins with the MEMORY\_FILL command (emulator command). If an error is detected, recheck the soldered IC socket and the location of pin 1.
3. The emulator connected to this user system interface cable supports two kinds of clock sources as the MCU clock: an emulator internal clock and an external clock on the user system. For details, refer to the H8S/2646 E6000 Emulator User's Manual (HS2646EPI61HE).
  - To use the emulator internal clock  
Select the clock in the emulator station as the system clock ( $\phi$ ), by using the CLOCK command (emulator command).
  - To use the external clock on the user system  
Supply the external clock from the user system to the emulator by inputting the external clock from the EXTAL on the cable head or connecting a crystal oscillator to the XTAL and EXTAL terminals. For details, refer to section 21, Clock Pulse Generator, in the H8S/2636 F-ZTAT™ Hardware Manual.

Figure 10 shows the oscillator circuit on the user system interface cable.



**Figure 10** Clock Oscillator Circuits

## Section 5 Notice

1. Make sure that pin 1 on the user system IC socket is correctly aligned with pin 1 on the cable head before inserting the cable head into the user system IC socket.
2. The dimensions of the recommended mount pad for the user system IC socket are different from those of the MCU.
3. This user system interface cable is specifically designed for the HS2646EPI61H emulator. Do not use this cable with any other emulator station.
4. To prevent breaking of wires in the cable body, do not place heavy or sharp metal objects on the user system interface cable.
5. While the emulator station is connected to the user system with the user system interface cable, force must not be applied to the cable head. Place the emulator station, user system interface cable, and user system as shown in the example in figure 11.

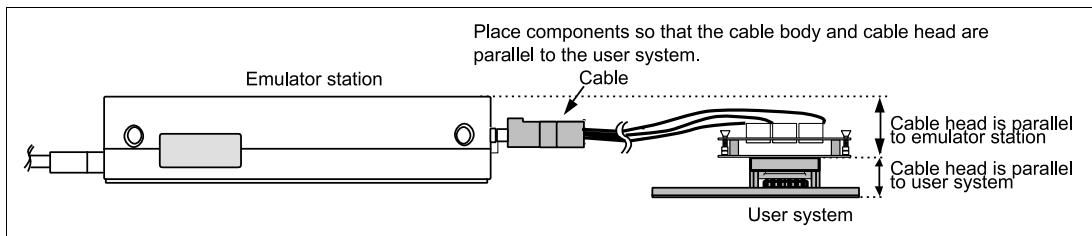

**Figure 11 User System Interface Cable Location Example**

6. The P1 jumper socket is used for testing. Do not remove the inserted jumper pin.

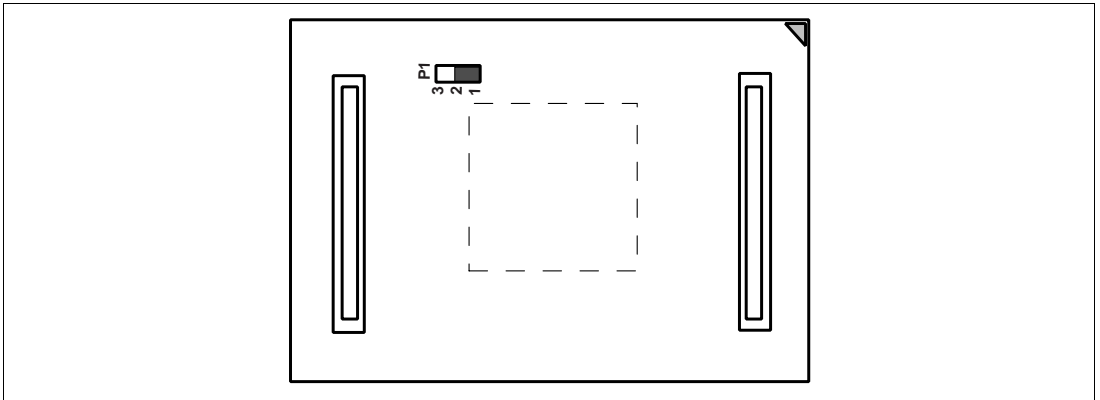

**Figure 12 P1 Jumper Socket**

---

**Renesas Microcomputer Development Environment System  
User's Manual  
H8S/2635 FP-128  
User System Interface Cable HS2635ECH61H**

Publication Date: Rev.1.00, June 10, 2005  
Published by: Sales Strategic Planning Div.  
Renesas Technology Corp.  
Edited by: Technical Documentation & Information Department  
Renesas Kodaira Semiconductor Co., Ltd.

Renesas Technology Corp. Sales Strategic Planning Div. Nippon Bldg., 2-6-2, Ohte-machi, Chiyoda-ku, Tokyo 100-0004, Japan

---



**RENESAS SALES OFFICES**

<http://www.renesas.com>

---

Refer to "<http://www.renesas.com/en/network>" for the latest and detailed information.

**Renesas Technology America, Inc.**

450 Holger Way, San Jose, CA 95134-1368, U.S.A  
Tel: <1> (408) 382-7500, Fax: <1> (408) 382-7501

**Renesas Technology Europe Limited**

Dukes Meadow, Millboard Road, Bourne End, Buckinghamshire, SL8 5FH, U.K.  
Tel: <44> (1628) 585-100, Fax: <44> (1628) 585-900

**Renesas Technology Hong Kong Ltd.**

7th Floor, North Tower, World Finance Centre, Harbour City, 1 Canton Road, Tsimshatsui, Kowloon, Hong Kong  
Tel: <852> 2265-6688, Fax: <852> 2730-6071

**Renesas Technology Taiwan Co., Ltd.**

10th Floor, No.99, Fushing North Road, Taipei, Taiwan  
Tel: <886> (2) 2715-2888, Fax: <886> (2) 2713-2999

**Renesas Technology (Shanghai) Co., Ltd.**

Unit2607 Ruijing Building, No.205 Maoming Road (S), Shanghai 200020, China  
Tel: <86> (21) 6472-1001, Fax: <86> (21) 6415-2952

**Renesas Technology Singapore Pte. Ltd.**

1 Harbour Front Avenue, #06-10, Keppel Bay Tower, Singapore 098632  
Tel: <65> 6213-0200, Fax: <65> 6278-8001



H8S/2635 FP-128  
User System Interface Cable  
HS2635ECH61H User's Manual



Renesas Technology Corp.  
2-6-2, Ote-machi, Chiyoda-ku, Tokyo, 100-0004, Japan